

Review Research Paper

Implications of mobile communication technologies (mct) in m-government: challenges, technology and applications

***VR Salkute, SR Kolhe and Ambedkar Veedhi**

National SCs Finance and Development Corporation 5th Floor, V.V. Main Tower, Bangalore-560 001
North Maharashtra University, UMAVI Nagar,
Email: srkolhe2000@gmail.com

Accepted 6 April, 2011.

The emergence of Mobile Communication Technologies (MCT) has enabled the government to transform from Electronic Government (e-government) to Mobile Government (m-government). This paper proposed a framework based on the theory of Task-Technology Fit (TTF) to understand MCT and their implications for m-government applications. Following the framework, we reviewed current MC technologies, categorized e-government tasks and reviewed and summarized existing m-government applications. To measure the degree of fit between MCTs and government tasks performed through them and its importance in the successful m-government implementation, we then discussed the benefits and challenges of m-government.

Keywords: Mobile Commerce Technologies; MCTs; Mobile Government; m-government; Electronic Government; e-government; Task-Technology Fit; TTF.

INTRODUCTION

Mobile Commerce Technology (MCT) which includes technological infrastructure for connectivity such as Wireless Local Area Network (WLAN) and Wireless Wide Area Network (WWAN) and mobile information devices such as mobile phones, Personal Digital Assistant (PDA) and laptop computers has emerged as the next wave in IT revolution (Varshney and Vetter, 2000). The number of mobile devices being used already exceeds 40-50% penetration rate for the entire world population (Lui, Zhenhue and et al., 2010). It is predicted that the number of mobile phones connected to the internet will exceed the number of internet-connected PCs in 2012 (Elliott and Phillips, 2004).

The emergence of MCT is not only changing the way of conducting business, as demonstrated by the fast growth of mobile commerce, but also enabling the transformation of the way governments deliver their services (Sharma and Gupta, 2004; Seeman et al., 2007). Since 1990s, public sector organizations across the globe, at both local

and national levels have been applying the E-Commerce technology and other Information and Communication Technologies (ICTs) in innovative ways to deliver services, engage citizens and improve internal efficiency, a practice commonly known as Electronic Government (e-government) (Eyob, 2004; Lee et al., 2005). The explosion in the use of MCT has forced the governments to prepare themselves to transit from e-government to Mobile Government (m-government). As an extension or supplement of e-government, m-government is broadly defined as a strategy and its implementation by the government to provide information, deliver services, engage citizens and improve efficiency using mobile devices (Moon, 2004). Field workers, customs inspectors, immigration agents and medical, law enforcement and military personnel can all benefit from accessing current data to make better, faster decisions (Sharma and Gupta, 2004). In India, there is great emphasis on the application of MCT by Central and state governments. Despite its great potential and positive expectations, m-government is still in the infancy stage and its applications are limited. Governments are proceeding to m-government applications with caution due to some issues, risks and

concerns of using MCT (Moon, 2004). Because, there is no law in 2011 specifically governing MCT except Foreign Investment Regulations which permit foreign investments in the B2B e-commerce sector. Although there is a general agreement about the areas where MCT can be effective in government sectors (e.g. Lallana, 2004; Moon, 2004; Sharma and Gupta, 2004), very little is known about how the government can best leverage the fast-developing MT for the myriads of government services. Such knowledge is important, as it will help the governments explore the opportunities (e.g. types of task that can be performed) presented by rapidly developing MTs and determine successful implementation of m-government applications. In this study we use theory of Task Technology Fit (TTF) to develop a framework for understanding MCT and its implications for m-government applications (Gebauer, Judith and et al., 2010). The objective of this study is four-fold: (1) to propose a framework to systematically analyse MCTs and their applications in government sectors; (2) to provide a review of existing m-government applications; (3) to analyse the level of fit between MCT used and tasks supported by the technologies in existing m-government applications and (4) to present an in-depth discussion of benefits, challenges and some insights regarding future directions of m-government applications.

M-Government: A Review

M-government is the subset of e-government (Lallana, 2004) and is implemented by the government to provide information and services to the government employees, citizens and other organizations through mobile devices (Lee et al., 2006). E-government refers to the strategic and systematic use of ICTs to promote efficient and effective government, facilitate easy access of government information and services and make governments more accountable to citizens (Im and Seo, 2005; Patelis et al., 2005).

MCT has two unique characteristics: 'mobility' and 'wireless'. Mobility, the most touted advantage of MCT, is enabled by the use of mobile devices that are portable and not restricted to desktops (Sharma and Gupta, 2004). Mobile devices typically include PDAs, laptops, cellular phones, tablet PCs and Blackberries. Wireless refers to the method of transferring information between a computing device such as a laptop or a PDA and a data source such as a government agency database server, without a physical connection (Sharma and Gupta, 2004).

Comparing to wired technologies, MCTs have some advantages. First, MCT removes time and space constraints by allowing access of critical information anytime and anywhere, thus enhances capabilities for communication, coordination, collaboration and knowledge exchange (Varshney and Vetter, 2000; Davis, 2002). Second, MCT helps decrease digital divide by

removing infrastructure constraints, which is especially important in countries with poor or non-existent wire infrastructure. Third, MCT removes cost constraint of possessing a computing device and accessing the internet, which narrows the societal gap in information access.

A perspective of understanding m-government

Prior research on technology innovation has pointed out the importance of fit between information technologies and the tasks to be supported, as a precursor to technology use and its subsequent benefits (Goodhue and Thompson, 1995; Dennis et al., 2001; Gabauer and Shaw, 2004). TTF model, which was proposed by Goodhue and Thompson (1995), suggests that a fit between the features and functions provided by the technology and the tasks to be supported will result in better performance. Thus, when a new information technology is introduced, the characteristics of the technology and the tasks that are to be performed by the users should be considered (Klaus et al., 2003). In the context of m-government, TTF suggests that a fit between the characteristics of MCTs and the government tasks they support must be ensured for successful implementation of m-government applications (Lui, Zhenhue and et al., 2010).

We propose a perspective, presented in Figure-1, as a means to analyze m-government. Based on this framework, we evaluate the technologies used in m-government and categorize e-government services that can be provided through MCTs. We then summarize existing m-government applications and discuss benefits and challenges of m-government applications based on the proposed framework.

Mobile technologies

The following sections discuss implementation of m-government with mobile devices and wireless connectivity offered by them.

Mobile devices

Mobile devices are portable and can be carried around by anybody at any time and at any place. Thus, 'mobility' is the key enabler of m-government applications. A mobile device enables the persons to get access to government information ubiquitously. It also allows government personnel to access the databases and update information on the spot, which is especially beneficial for field investigators. Some of the widely used mobile devices are as follows:

- Mobile phone can be used to connect to the internet through analog or digital networks. Statistics show that

The main theory of TTF, Goodhue and Thompson (1995) is

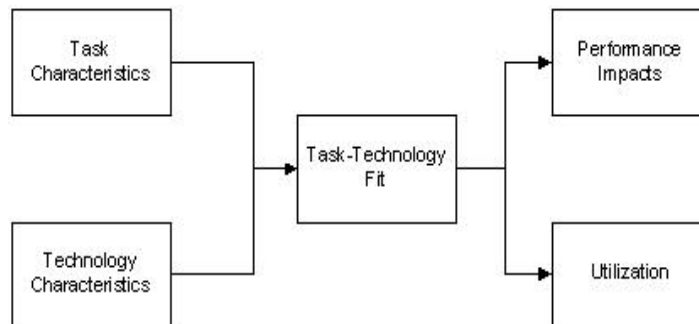

Source: Goodhue and Thompson, (1995)

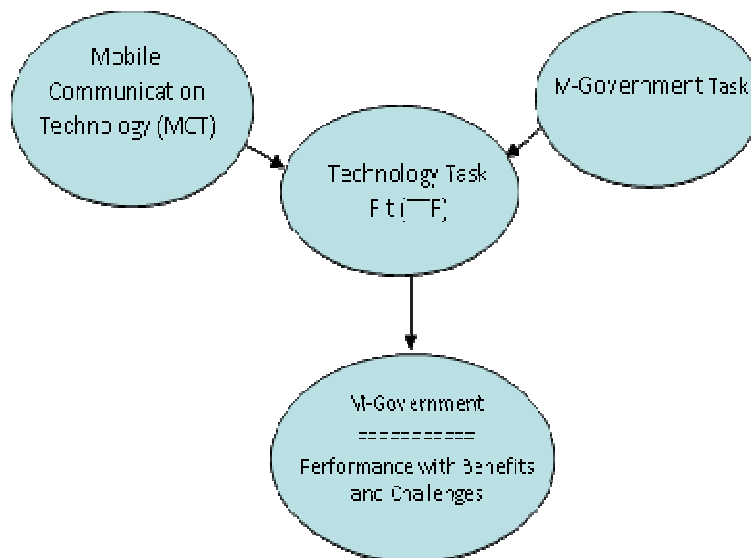

Figure 1

nearly 32 billion messages per month were transmitted globally via SMS in February 2004 (Kumar, 2004).

- Smart phones refer to the combination of mobile phones and PDAs, which are becoming increasingly popular as they are becoming less expensive.
- Personal Digital Assistants (PDAs) are small-size computing devices that can typically provide services such as embedded e-mail, calendaring, address book, tasks and memo applications.
- Tablet PC is a wireless personal computer. A tablet PC is similar in size and thickness to a notepad. It not only can function as a laptop or a PC, but also has a touch screen which allows users to take notes on with natural handwriting using a stylus or a digital pen.
- Blackberry is a hand-held device developed by Research in Motion. The major function of Blackberry is

its wireless e-mailing capability but it can also be used as a PDA that maintains personal calendar and address

book. It can also be configured for use as a pager and for internet access.

Wireless networks

'Wireless' refers to the method of transferring information between a computing device and a data source without a physical connection (Sharma and Gupta, 2004). Wireless networking technology is especially appropriate for situations where installation of physical media is not feasible and/or on-the-spot access to the information is required (Malladi and Agrawal, 2002). There are five main categories of wireless networks which is described in Table 1

Table 1 Summary of wireless networks

Network	Technology	Description	Coverage area	Applications	User fee
WLAN	Wi-Fi	IEEE 802.11 for wireless LAN	building/campus (30 feet)	Voice Email Text SMS	No
WPAN	Bluetooth	Open wireless spec for personal area network in short range (802.15)	A few feet (10 feet)	Synchroni-sation Data exchange	No
Wireless Internet		3G and 4G	Global	Content rich video Voice E-mail Internet access	Yes
WMAN	WiMax	Wireless DSL/cable(802.16) and mobile access (802.16e)	Building to Buildg (30 miles)	Voice E-mail Internet access	Yes
WWAN	Cellular	Analog and digital networks that transfer signals along transmitters	National	Voice E-mail Tex-messaging	Yes

Classification of m-government tasks

M-government is the extension of e-government to mobile platforms. It is concerned with the final delivery of e-government services to ordinary citizens, businesses and government employees using mobile platforms. M-government services can be classified based on the following criteria:

- Parties involved – m-government practices can be classified into four categories: government to citizen (G2C), government to business (G2B), and government to government (G2G).
- Types of transaction performed – m-government practices are classified into three categories: informational, transactional and operational functions (Norris and Moon, 2005). Informational functions include information publishing and updates and alert messages. Government can provide general information through online publishing and broadcasting. Government can also send government alerts to end-users, proactively or automatically, through e-mails or SMS. Transactional functions allow users to perform transactions, such as online procurement and payments, renewal of permit/licences, voter and property registration, through mobile devices. Operational functions refer to internal governmental operations. Current m-government applications Goodhue and Thompson (1995) suggested that information systems have a positive effect on performance if and only if there is a match between their functionality and the task requirements of users. The fit is the degree to which a technology assists an individual in performing his or her portfolio of tasks. Systems that have higher TTF will lead to better performance. The fit between the available MCT and m-government tasks that end-users perform by using them determines the

success of existing and future m-government applications. Current m-government applications, categorized into several groups based on tasks and technologies they use, are described as follows:

G2C: informational

Public access to governmental services or information.
Emergency notification:

C2G: operational

E-democracy:

G2C: informational/operational

Location-based services:

Information Technology: operational

Field inspections.

Evaluating m-government applications

Based on the framework proposed in this paper, we reviewed MCT, categorized e-government tasks and summarized m-government applications, which are classified based on task performed and technology used. The framework proposed in this paper also provides a foundation for analyzing m-government applications, that is, to assess benefits and challenges of m-government applications. We need to examine the fit between MCT and the e-government tasks that this technology can support. If there is a match between the features offered by the technology and the tasks to be supported, governments can benefit significantly from expanding e-government services into the mobile platforms. On the other hand, a misfit between the m-government applications and MCT, as well as the limitations and

drawbacks of MCT, may pose challenges to expand e-government services into m-government and successful implementation and usage of m-government.

Advantages of m-government

The most obvious benefit of MCTs is the increased scope of delivery of government information and services, both geographically and in terms of the number of people served. Second, m-government can increase efficiency and effectiveness of government employees. Finally, m-government opens up additional opportunities for citizen participation in decision- and rule-making, thus promoting democracy.

Challenges of m-government

Although MCTs have great potential for m-government applications, there still exist some obstacles to their wide diffusion.

Security and privacy: Security and privacy have been considered as main barriers to e-government (Norris and Moon, 2005). These two issues are more of a Problem for m-government applications (Sharma and Gupta, 2004).

Accessibility: The wireless network, at its infancy right now, has limited coverage area. As government agencies pursue plans to provide access to government information and services via text to wireless access devices, they should also facilitate the information to be more accessible for all citizens via the web or other communication technologies (Sharma and Gupta, 2004).

Usability: In spite of many advantages of mobility, mobile devices have a number of inherent limitations such as: (1) small screens and small key pads, (2) limited computational power and memory, (3) short battery life, (4) complicated text input mechanisms, (5) higher risk of data storage and transaction errors, (6) lower display resolution, (7) less surfing ability, (8) unfriendly user-interfaces and (9) limitations in graphical capabilities (Siau and Shen, 2003).

Application Infrastructure: This issue is two-fold: (1) e-government applications upon which m-government applications are built and (2) different browser platforms for wired and wireless internet access. M-government must be built on a sound e-government infrastructure i. e. the backbone of digitalized government must be present to optimize the mobile/wireless technologies for final delivery of government information and services. Second, there are multiple platforms for mobile/wireless applications ranging from Wireless Application Protocol (WAP) and GSM to DoCoMo's (Japan) I-Mode.

CONCLUSIONS

This paper proposed a framework based on TTF to help better analyze how MCT can support government tasks. Following the framework, we reviewed current MCTs, categorized e-government tasks and reviewed existing m-government applications. To measure the degree of fit between MCTs and government tasks performed through them and its importance in the successful m-government implementation, we then discussed the benefits and challenges of m-government.

Currently, m-government applications are generally restricted to G2C and IT and mainly support simple information exchange between government agencies and citizens or facilitate uncomplicated operations performed by government employees. Nevertheless, we do believe m-government has a bright future. With the ever faster development in MCT, more innovative m-government applications will become possible and m-government will certainly move from the initial stage to the fast growth stage resulting in widespread adoption and diffusion. To successfully implement m-government, governments need to carefully monitor and analyze what the end-users want and what will be their benefit from using m-government application.

REFERENCES

- Dennis AR, Wixon BH, Vandenberg RJ (2001). 'Understanding fit and appropriation effects in group support systems via meta-analysis', *MIS Quarterly*, 25(2):167-193.
- Eyob E (2004). 'E-government: breaking the frontiers of inefficiencies in the public sector', *Electronic Government, an Int. J.* 1(1): 107-114.
- Gebauer J, et al (2010). *Task Technology Fit for mobile information systems. J. Inform. Tech.* 25:259-272.
- Gabauer J, Shaw MJ (2004). 'Success factors and impacts of mobile business applications: results from a mobile e-procurement study', *Int. J. Elect. Commerce*, 8,(3):19-41.
- Goodhue DL, Thompson RL (1995). 'Task-technology fit and individual performance', *MIS Quarterly*, 19:213-236.
- Im JJ, Seo JW (2005). 'E-government in South Korea: planning and implementation', *Electronic Government: An Int. J.* 2(2):188-204.
- Klaus T, Gyires T, Wen J (2003). 'The use of web-based information systems for non-work activities: an empirical study', *Human Systems Management*, 22:105-114
- century', *International Journal of Mobile Communications*, 2(1):67-86.
- Lallana EC (2004) E-government for development. Available online at: <http://www.egov4dev.org/mgovapplic.htm>
- Lee SM, Tan X, Trimi S (2005) 'Current practices of leading e-government countries', *Communications of the ACM*, 48(10):99-104.
- Malladi R, Agrawal DP (2002). 'Current and future applications of mobile and wireless networks', *Communication of the ACM*, 45(10):144-146.
- Moon J (2004) From E-Government to M-Government? Emerging Practices in the Use of MT by State Governments, IBM Center for the Business of Government.
- Seeman ED, O'Hara MT, Holloway J, Forst A (2007) 'the impact of government intervention on technology adoption and diffusion: the example of wireless location technology', *Electronic Government: An Int. J.* 4(1):1-19.
- Sharma S, Gupta JN (2004). 'Web services architecture for m-government: issues and challenges', *Electronic Government, an Int. J.* 1(4):462-474.
- Siau K, Shen Z (2003). 'Mobile communications and mobile services', *Int. J. Mobile Commun.* 1(1/2):3-14.

Varshney U, Vetter R (2000). 'Emerging mobile and wireless networks', *Communications of the ACM*, 43(6):73–81.