

*Full Length Research paper*

# Clinical and molecular genetic findings in a Friedreich's Ataxia Tunisian family

Yosr Bouhlal<sup>1</sup>, Ghada El Euch-Fayeche<sup>1</sup>, Fayçal Hentati<sup>1</sup>, Rim Amouri<sup>1</sup>

<sup>1</sup> Laboratoire de Neurobiologie Moléculaire et de Neuropathologie, Institut National de Neurologie, 1007 la Rabta Tunis – Tunisia

Accepted 5 January, 2010

The most common mutation in Friedreich's ataxia (FA) is an expanded GAA trinucleotide repeat in the first intron of the FXN (Frataxin) gene. A clear correlation between the size of the expanded alleles and phenotype severity was found as the major determining factor. The objective of this study was to report clinical and molecular data of 10 patients homozygous for pathological FXN GAA expansions. Clinical evaluation was performed for all the patients. GAA expansions were detected by Tripled Primed PCR (TP-PCR) and GAA allele size was estimated by Long Range PCR (XL-PCR). Clinical features were variable within the same family with no correlation between age at onset, worsening score or tendon reflexes status. All patients were homozygous for the pathological GAA expansions. No obvious relationship was found between the different clinical features and size of GAA repeats. In conclusion, factor controlling phenotypic expression in FA may be related to other factors than FXN GAA expansions.

**Key Words:** Friedreich's ataxia, GAA expansion, intrafamilial variability.

## Introduction

FA(FA) is the most common inherited autosomal recessive ataxia with an estimated prevalence in Tunisia of 3.5/100.000 (Triki et al 1989). Diagnostic criteria for FA have been developed in two large series by Geoffroy et al (1976) and Harding (1981). The responsible gene FXN encodes for a widely expressed mitochondrial protein called Frataxin (Campuzano et al 1996) which maps to chromosome 9q23 (Chamberlain et al 1988). The most common mutation is an expanded GAA trinucleotide repeat in the first intron of the FRDA gene (Campuzano et al 1996). Healthy persons are characterized by 6 to 27 GAA repetitions, while FA patients carry 200 to 1700 repeats. Less than 5% of FA patients are heterozygous for expanded alleles and point mutations in FRDA gene (Cossee et al 1999). Homozygous patients for the GAA pathological expansion have two alleles, a small one (GAA1) and a larger one (GAA2). A clear correlation between the size of GAA1 allele and phenotype severity was found as the major determining factor (Filla et al 1996, Schols et al 1997, McCabe et al 2000, Mateo et al 2004).

The objective of this study is to report a correlation between ten Tunisian patients with pathological FXN GAA expansions and their clinical features.

## Patients and methods

### Patients

10 patients belonging to a large consanguineous Tunisian family with a total of 21 family members (Figure 1), were selected from the Department of Neurology FRDA database. The index patient (IV:3) showed typical FA phenotype according to Harding's criteria (Harding 1981) with:

- Autosomal recessive inheritance.
- Onset before age of 25.
- Progressive cerebellar ataxia.
- Dysarthria.
- Absence of tendon reflexes in lower limbs.
- Pyramidal weakness and Babinski sign.
- Homozygous pathological GAA expansion.

### Clinical investigations

The following clinical factors were specified for each patient: The cerebellar syndrome evaluated according to the International Cooperation Rating Scale (ICAR) from 0 to 100 (Trouillas et al

\*Corresponding author email: [yosr.bouhlal@gmail.com](mailto:yosr.bouhlal@gmail.com)

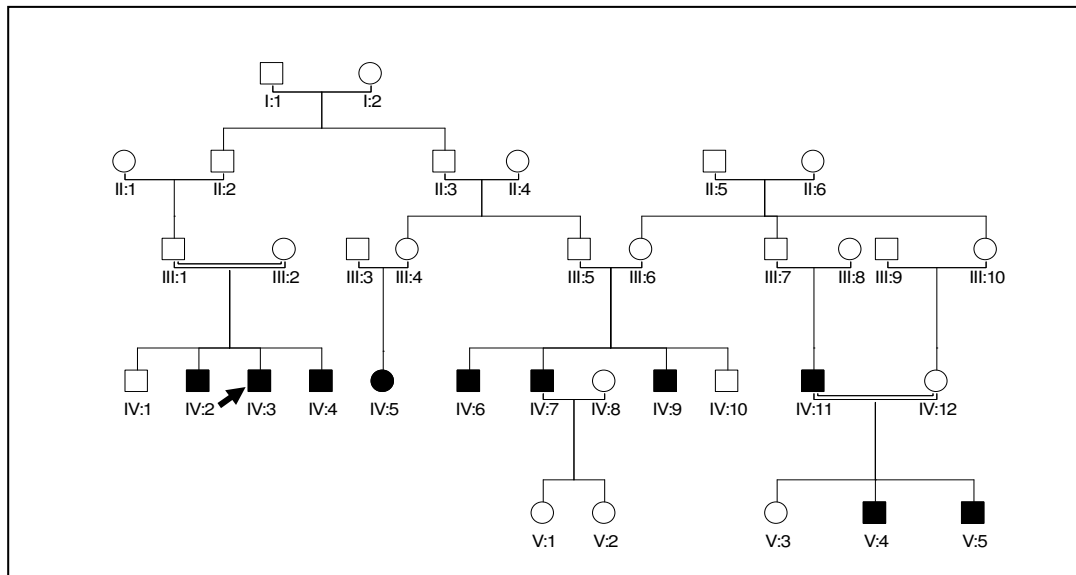

**Figure 1.** Pedigree structure of the studied family (➤ proband)

1997); the worsening cerebellar syndrome score, calculated by ratio of cerebellar score on duration of the disease; the tendon reflexes status in the four limbs; evaluation of the pyramidal syndrome by the degree of spastic gait; the degree of amyotrophy in all four limbs; deep sensory disturbances (proprioception and vibration sense); presence of joint deformities and fundoscopic examination.

#### Laboratory investigations

The peripheral nerve conduction, sensory evoked potentials, and visual-evoked potentials were recorded in most patients using routine techniques (Zouari et al 1998). Visual evoked potentials were measured by monocular stimulation with an alternating black-and-white checkerboard pattern. The amplitude and the latency of the P100 wave were recorded.

Routine laboratory tests, including blood vitamin E level, cerebrospinal fluid analysis, electrocardiography, echocardiography, and cerebral computed tomographic scan, were carried out in most patients.

#### Molecular analysis

Blood samples were collected from the 10 patients and DNA extracted using standard procedure. GAA expansions were detected and quantified for all the patients.

#### Detection of GAA expansion

GAA expansions were detected by TP-PCR (Triple Primed PCR, Warner et al 1996). Amplified fragments were electrophoresed on ABI Prism 310 sequencer and then analysed by Genescan Analysis Software.

#### Determining size of GAA expansion

To estimate the size of the GAA repeat, PCR was performed using

the GAA repeat flanking primers (McCabe et al 2000) with Go-Taq polymerase and the Applied BioSystems XL-PCR program. This generate a PCR product of  $(500+3n)$  base pair, where  $n$  is the number of GAA repeats. The size of GAA repeat was estimated using the Biocapt Software.

## Results

### Clinical findings (table 1)

The studied family was composed by 21 members including 10 patients with a male predominance (9 men and 1 woman). The mean age at examination was 31.6 years  $\pm$  8.5 (range = 21 to 47 years).

The clinical features associated progressive cerebellar syndrome with dysarthria and a pyramidal syndrome in all patients but with a variability in several clinical parameters, between family members. The age at onset varied from 7 to 25 years (mean age of onset 13.6 years  $\pm$  5.1). Tendon reflexes in lower limbs displayed variable features. They were found to be absent in seven patients and brisk in one (patient IV:2). For one the patient (patient IV:11), knee reflexes were present whereas ankle reflexes were abolished. Another patient (patient IV: 4), tendon reflexes were brisk at age of 20 and became abolished by the age of 31. The cerebellar score ranged from 24 to 59, mean score of  $45.8 \pm 13.9$  and the worsening score ranged from 1.43 to 6.80, mean score  $2.92 / \text{year} \pm 1.49$ .

No correlation was found between different clinical features. Severity of the disease was variable between all patients (figure 2). The age at onset did not correlate with the worsening score (figure 3). Patients sharing similar age at onset displayed variable worsening scores

**Table 1.** Clinical and Molecular findings

Patients		IV :2	IV :3	IV :4	IV:5	IV :6	IV:7	IV :9	IV:11	V:4	V:5	
<b>Clinical findings</b>	Age at examination	40	35	31	24	37	34	25	47	21	22	
	Age of Onset	12	14	15	8	16	7	11	25	11	17	
	Age at WCB	35	33	24	22	-	31	-	34	-	-	
	Cerebellar score/100	59	57	57	53	30	55	32	57	24	34	
	Score/duration	2.11	2.71	3.56	3.31	1.43	2.04	2.29	2.59	2.40	6.80	
	Knee reflexes	++	-	++ to -	-	-	-	-	-	+	-	-
	Ankle reflexes	++	-	++ to -	-	-	-	-	-	-	-	-
	ECG, echocardiography	NP	LV Hypertrophy	NP	Normal	NP	NP	NP	NP	NP	Normal	Normal
<b>Molecular findings</b>	Protein of LCR rate	0.43	0.3	0.19	0.23	NP	NP	NP	NP	0.56	0.51	
	GAA1 size (bp)	1833	1833	2678	2073	2073	1976	2366	2112	2270	2193	
	GAA2 size (bp)	2545	2863	3334	2954	2954	2909	3161	2366	3843	2193	
	Number of GAA 1 repeats	444	444	726	524	524	492	622	537	590	564	
	Number of GAA 2 repeats	682	788	945	818	818	803	887	622	1114	833	
	Mean GAA size	563	616	835	671	671	648	755	580	852	699	

- : Abolished ; + : present ; ++ : Brisk ; NP : not preformed

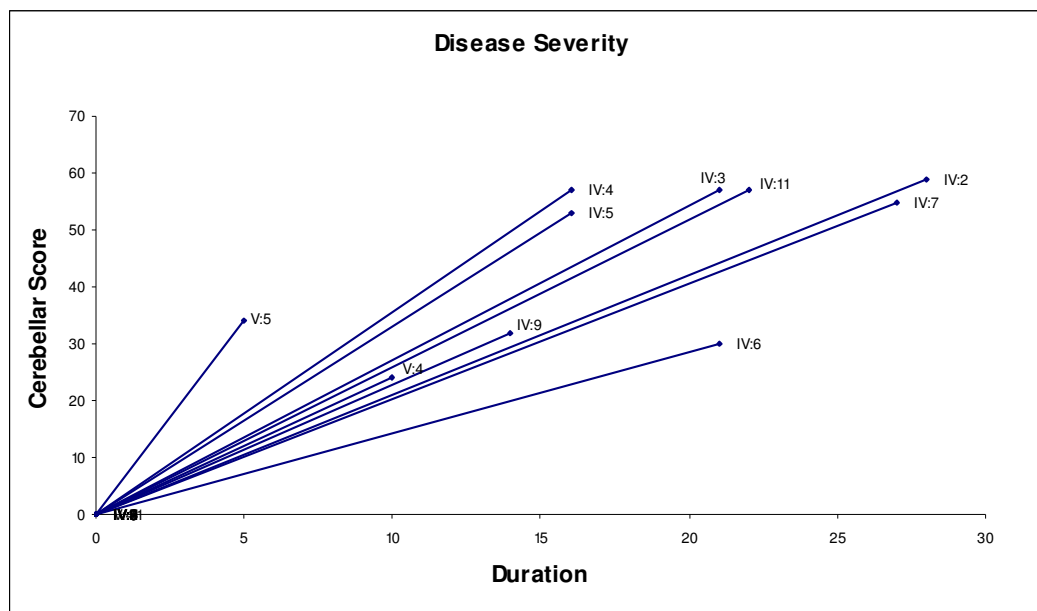

**Figure 2.** Variability of the disease severity between patients.

(patients IV:6 and V:5) whereas patients with close worsening score, had dissimilar age at onset (patients IV: 4 and IV: 5). The presence or the absence of tendon reflexes did not correlate with the age of onset, the disease progression or the wheelchair-bound (WCB) age. ECG and echocardiography showed left ventricular hypertrophy in one (patient VI:3) out of the 4 explored patients. Glycaemia was normal in all patients.

### Molecular finding

All patients share the homozygous pathological GAA expansions. GAA allele size varied between patients with a mean GAA1 size of  $546.7 \pm 85.11$  (range, 444 to 726) and a mean GAA2 size of  $831 \pm 135.43$  (range, 622 to 1114) (Table1).

No evidence of correlation was found between GAA

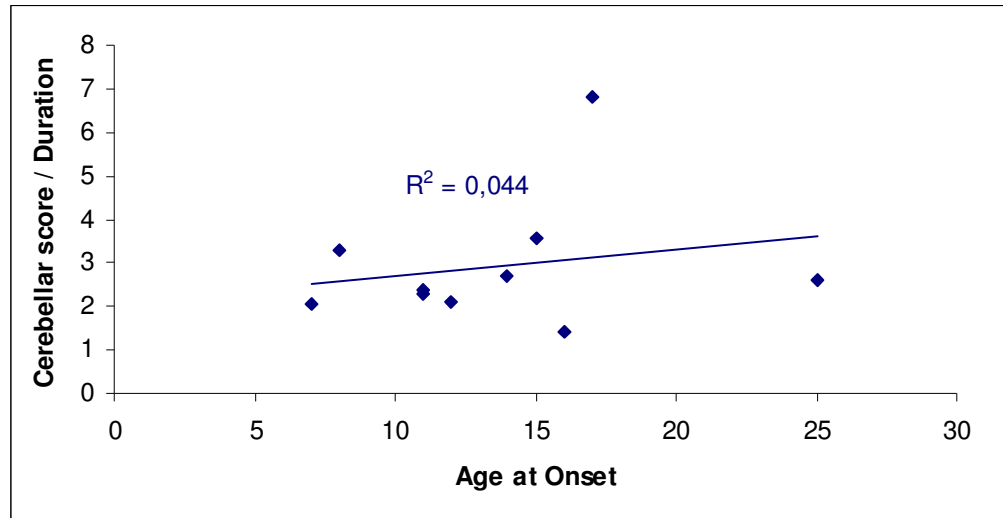

**Figure 3.** Scattergram of the **worsening score** by the age at onset.

size and ages at onset, worsening scores or ages at WCB ( $R^2 < 0.5$ ) (Figure 4A, 4B and 4C respectively). Patients with the same worsening score could have different number of GAA repeats (patients IV: 3, IV: 4 and IV: 11). Whereas patient with the highest worsening score (patient IV: 5) had close GAA1 size as patients with lower scores (patients IV: 5 score and IV: 11) (Table 1). Patient IV: 4 had the highest GAA1 size (726 repeats) associated with the lowest protein LCR rate. He had also a relatively high disease worsening score (3.56 point per year). For this patient, tendon reflexes were brisk at age of 20 and abolished at thirty-one.

Tendon reflexes did not correlate with the number of GAA allele repeats. For patient IV: 2 with brisk knee and ankle reflexes, GAA size was nearly equal to patient IV:3 with areflexia at lower limbs.

A weak correlation was suspected between WCB (WheelChair-Bound) ages and GAA2 size ( $R^2 = -0.58$ ) but number of patients was not so significant to allow to confirm such correlation. (figure 4).

## Discussion

Friedreich ataxia is one of the most common diseases that due to trinucleotide expansions (Campuzano et al 1996). Since the identification of this Frataxin mutation (Campuzano et al 1994) several reports studied correlations between the GAA expansion size and the severity of the disease. All suggest an inverse correlation between GAA1 repeat length and age at onset, cerebellar and worsening score, age at WCB and tendon reflexes features (Filla et al 1996, Schols et al 1997, McCabe et al 2000, Mateo et al 2004).

Patients reported in this paper shared pathological Frataxin gene GAA expansions and displayed obvious intrafamilial phenotypic variability according to the age at

onset, the worsening cerebellar score and tendon reflexes feature. However we did not found, as previously reported, a relationship between earlier ages at onset and severity of the course of the disease (De Michele et al 1994). Tendon reflexes were variable since they were present in 3 out of 10 patients with different status (present to brisk) and no evidence of correlation with other clinical parameters such as age at onset or the severity of the course. Whereas, several previous studies have demonstrated that preservation of tendon reflexes was correlated with age at onset. Patients with late onset (LOFA: Late Onset Friedreich Ataxia) seems to preserve tendon reflexes (De Michele et al 1994, Ragno et al 1997, Coppola et al 1999). It was also demonstrated that patients with FARR (Friedreich Ataxia with Retained Reflexes) seem to show a later age at onset when compared to classical FA patients (Durr et al 1996, Schols et al 1997, Coppola et al 1999, Mateo et al 2004). The cerebellar syndrome course was also variable between the 10 patients reported here. Patients with the same age at onset displayed a largely different worsening scores which were in contrast with previous findings in which authors have demonstrated an inverse correlation with age at onset and disease progression (Ragno et al 1997).

Molecular findings showed variability in GAA allele size within all the reported patients. The GAA allele size variability was widely reported in several studies and was found to correlate with different clinical parameters. Some authors have demonstrated an inverse correlation between age at onset and GAA1 allele size (Filla et al 1996, Durr et al 1996, Montermini et al 1997). Others suggested that preservation of tendon reflexes was correlated with GAA allele size (Durr et al 1996, Schols et al 1997, Coppola et al 1999, Mateo et al 2004). Disease severity was also correlated with GAA allele size and it

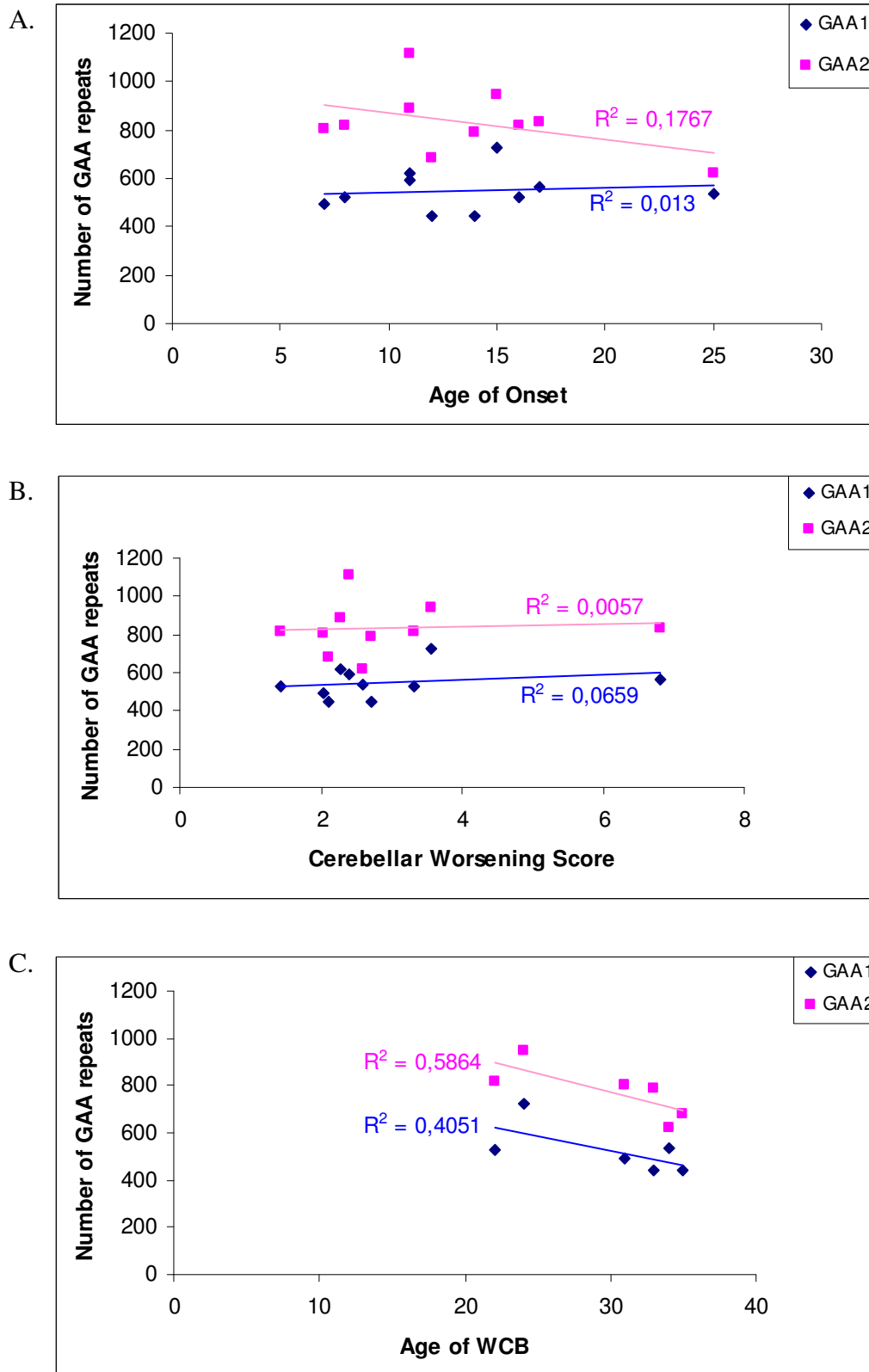

**Figure 4.** Correlation between GAA1, GAA2 allele sizes and different clinical features within the studied family: A, Correlation between GAA1, GAA2 allele sizes and age at onset. B, Correlation between GAA1, GAA2 allele sizes and worsening score, C. Correlation between GAA1, GAA2 allele sizes and WCB age.

was demonstrated that GAA1 size was strongly correlated with the progression of the disease and the WCB age (Durr et al 1996, Schols et al 1997). In the reported family, the variability of GAA allele size did not seem to have a significant impact in the clinical parameters as the age of onset, the tendon reflexes feature or the severity of the course of the cerebellar syndrome. However, WCB ages seemed to inversely correlate with GAA2 size but number of patients was not significant to confirm such relationship.

In conclusion, we report here a Tunisian family with 10 FA patients sharing pathological Frataxin gene GAA expansions and displaying an important phenotypic intrafamilial variability. No obvious relationship was found between the age at onset, the tendon reflexes feature, the severity of the course of the disease and size of GAA repeats. Since the number of patients was not significant enough, the addition of more patients in this study could confirm this absence of correlation. Factor controlling phenotypic expression in FA may be more complex than usually believed and may be related to other factors than Frataxin gene expansions.

### Acknowledgement

The authors thank the family for participating in this study and Dr. Adel Driss (Morehouse School of Medicine, Atlanta) for his contribution in the correction of English.

### References

- Campuzano V, Montermini L, Molto MD (1996). Friedreich's ataxia: autosomal recessive disease caused by an intronic GAA triplet repeat expansion. *Sci.* 271: 1423-142.
- Chamberlain S, Shaw J, Rowland A,(1988) . Mapping of mutation causing Friedreich's ataxia to human chromosome 9. *Nat.* 334: 248-250.
- Coppola G, De Michele G, Cavalcanti F (1999). Why do some FA patients retain tendon reflexes? A clinical, neurophysiological and molecular study. *J. Neurol.* 49: 353-357.
- Cossee M, Durr A, Schmitt M (1999) .Friedreich's ataxia: point mutations and clinical presentations of compound heterozygotes. *Ann Neurol* 45:200-206.
- De Michele G, Filla A, Cavalcanti F (1994). Late onset Friedreich's disease: clinical features and mapping of mutation to the FRDA locus. *J. Neurol. Neurosurg. Psychiatr.* 57: 977-979.
- Durr A, Cossee M, Agid Y (1996) .Clinical and genetic abnormalities in patients with Friedreich's ataxia. *N. Engl. J. Med.* 17; 335(16):1169-1175.
- Filla A, De Michele G, Cavalcanti F (1996). The relationship between trinucleotide (GAA) repeat length and clinical features in Friedreich ataxia. *Am. J. Hum. Genet.* 59(3):554-60.
- Geoffroy G, Barbeau A, Breton G (1976). Clinical description and roentgenologic evaluation of patients with Friedreich's ataxia. *Can. J. Neurol. Sci.* 3: 279-286.
- Harding AE (1981) Friedreich's ataxia: a clinical and genetic study of 90 families with an analysis of early diagnostic criteria and intrafamilial clustering of clinical features. *Brain* 104: 589-620.
- Mateo I, Llorca J, Volpini V, Corral J, Berciano J, Combarros O (2004) Expanded GAA repeats and clinical variation in Friedreich ataxia. *Acta Neurol. Scand.* 109(1):75-8.
- McCabe DJ, Ryan F, Moore DP (2000). Typical Friedreich's ataxia without GAA expansions and GAA expansion without typical Friedreich's ataxia. *J. Neurol.*247(5):346-55. Erratum in: *J Neurol.* 247(6):483.
- Montermini L, richter A, Morgan K(1997). Phenotypic variability in Friedreich ataxia: role of the associated GAA triplet repeat expansion. *Ann. Neurol.* 41: 675-682.
- Ragno R, De Mchele G, Cavalcanti F (1997). Broadened FA phenotype after gene cloning. Minimal GAA expansion causes late-onset spastic ataxia. *Neurol.* 49 (6) : 1617-1620.
- Schols L, Amoiridis G, Przuntek H, Frank G, Epplen JT, Epplen C (1997). Friedreich's ataxia. Revision of the phenotype according to molecular genetics. *Brain* 120(Pt 12): 2131-40.
- Triki C (1989) Etude clinique, génétique, épidémiologique de 188 foyers de Maladie de Friedreich et d'Hérédo-Ataxie Cérébelleuse de Pierre-Marie, en Tunisie. [Thèse de Médecine, Sfax-Tunisie]
- Trouillas P, Takayanagi T, Hallett M(1997). International Cooperative Ataxia Rating Scale for pharmacological assessment of the cerebellar syndrome. The Ataxia neuro-pharmacology Committee of the world Federation of neurology. *J. Neurol.Sci.* 145:205-11.
- Warner J, Barron L, Mandel J, Koenig M (1996). Detection of large (GAA)<sub>n</sub> repeat expansions by fluorescent PCR. *J. Med. Genet.* 33: 1022-1026.
- Zouari M, Kefi M., Ben Hamida C (1998). Electrophysiology and nerve biopsy: a comparative study in Friedreich ataxia phenotype with vitamin E deficiency. *Neuromuscul. Disord.* 8: 416- 425.